



DURATIQUÉ™

*Stainless Steel
Antique Hardware*

Book Edition D.05

SUITED HARDWARE FOR
TRADITIONAL DOORS &
WINDOWS



COASTAL

Shaping the future.

Our Sense of Purpose

The shape of things to come

Perfect
Fit
Guaranteed

The basis for our
decision making.

Superior
Standards
Always

The principle behind
our actions.

Ultimate
Lasting
Performance

The status we want
to achieve.

Born on the rugged shores of Cornwall back in 2003, but opening doors and windows globally, Coastal Group is a family owned business which specialises in the design and manufacture of precision-made hardware solutions for external doors and windows.

We continuously innovate in the design and manufacture of every piece to ensure it enhances the look and improves the performance and durability of the doors and windows they're fitted to.

Consistently. Every time.

Loren Jenner

Managing Director, Coastal Group



DURATIQUE™ - Your Ultimate Antique Hardware - Made from Stainless Steel.

DURATIQUE™ brings you many benefits:

- No more issues of rusting black antique hardware - manufactured from a base material of Stainless Steel to prevent it corroding.
- DURATIQUE™ has been successfully Salt Spray Tested to Class 5.
- Ideal for use where corrosion levels are high such as coastal environments and with acidic timber.
- No more inconsistent product making it time consuming to fit - CNC machined fixing screw and lever locations. This ensures they're in a consistent location - enabling you to batch produce the doors and fit the hardware quicker.
- No more sagging handles and rattling spindles - high quality dual sprung mechanism and spindle ensures a nice positive action and returns the handle consistently to its original position.
- Part of a suited range of antique door hardware made from stainless steel.

The DURATIQUE™ brand is owned, manufactured and sold by:



COASTAL

Shaping the future.

www.coastal-group.com

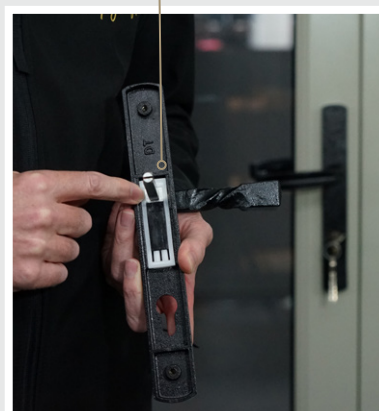
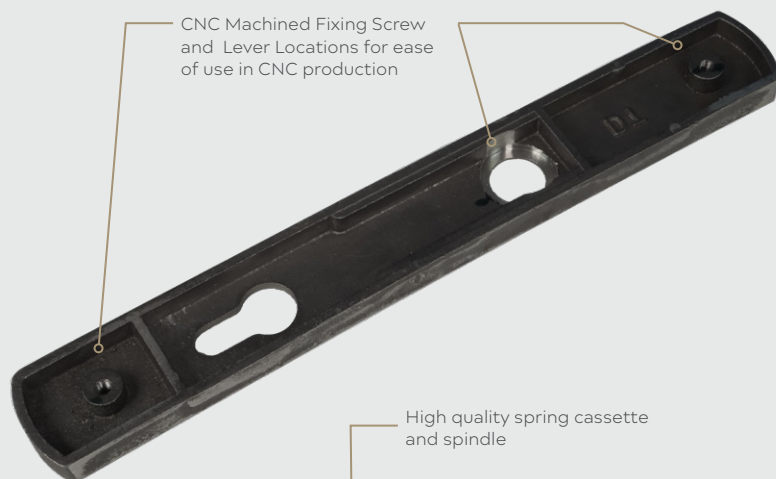



HOW WE CAN HELP YOU



Bespoke Solutions

Looking to source the right door or window product to fulfil your need, or one which meets your high performance standards? We're versatile and tailor our way of working to suit your individual needs.

Through combining our skills and capabilities we work with many large system houses, high-end joinery manufacturers, fabricators and architects to provide tailored products and solutions, like we can for you, as and when needed.

We're clear and focus on your priorities, and always aim to deliver the best possible solutions in the easiest possible way. How? By focussing not just on 'doing good', but also on 'feeling good' and caring about what you want, delivering it in the most appealing way.

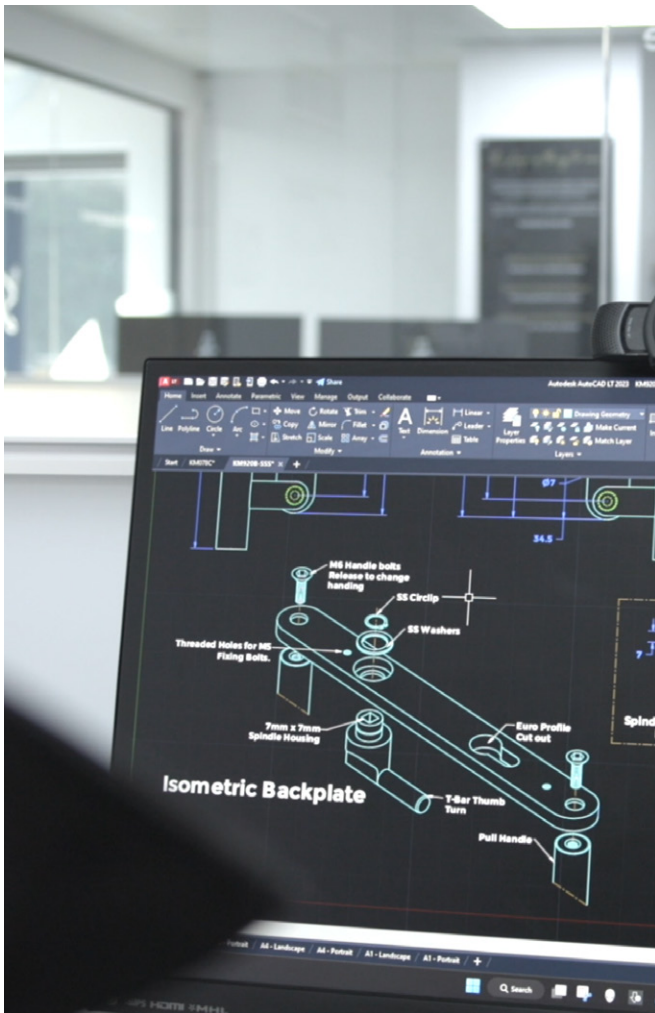

Design and Development

We're constantly scouring the marketplace for new consumer trends, end-user needs and technological advances, as well as keeping up to date with the latest regulations. Where existing door and window hardware and designs have become outdated or no longer meet changing customer needs we work to provide you solutions.

Through perpetual innovation our Research and Development Team are always working to move the door and window industry, and your business, forward by being ahead of the curve in terms of materials, products, fixtures and finishes.

Long-term value is what we design, develop and deliver to you.

Next Day Delivery

Great Service and Fast Delivery are as important to you as they are to us and we continue to invest to provide you with an industry-beating service. Our new Distribution Centres and Warehouse Management System have enabled us to increase and improve our stockholding and our 'On Time In Full' delivery service.

All of our core product range is held in stock for fast delivery. All stock item orders placed before 3pm are dispatched the same day and are usually delivered the next working day. If required, your delivery can be sent straight to site or an alternative location, e.g. to your client.



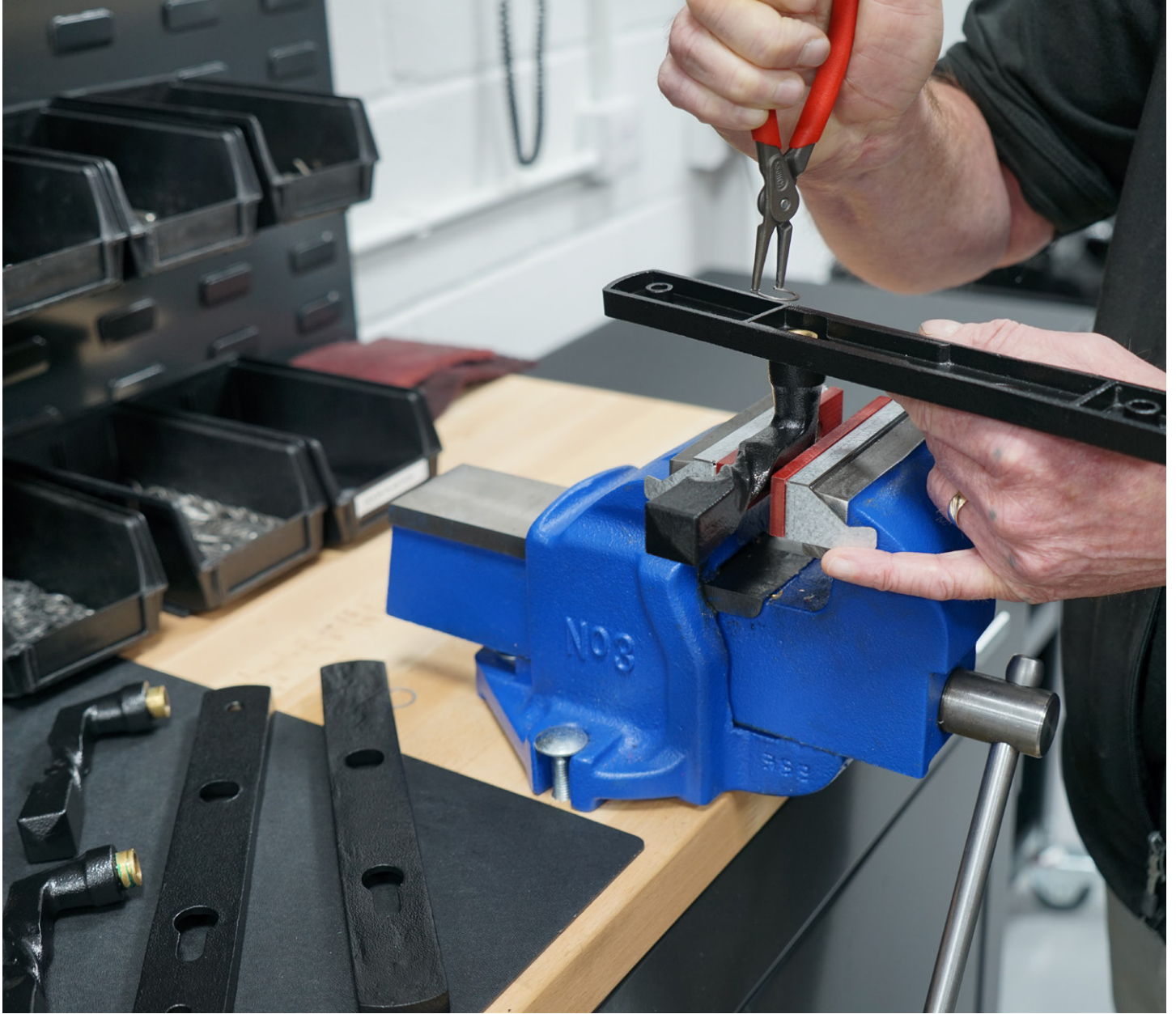

In-house Design and Build - Delivering You Quality

We're fanatical about ensuring our door and window hardware provides ultimate lasting performance. To ensure we deliver you hardware which lives up to our brand values, and doesn't let your brand down, we retain control of each step of the process - from design, to sourcing quality components from around the globe and build of the product.

Our range of door and window hardware designed and built in-house in the UK from components manufactured by specialists around the globe continues to grow - providing you with peace of mind that you're purchasing quality hardware from a stable supply chain.



Some examples of DURATIQUE™ products built in-house

Our team of trained technicians are dedicated to ensuring the products we deliver live up to our vision of:

- Perfect Fit Guaranteed
- Superior Standards Always
- Ultimate Lasting Performance

Shown here are our DURATIQUE™ Lever Door Handles going through assembly and final quality checks.

Once passed and approved they're packaged up and our 'Quality Seal' is applied, ready for delivery.

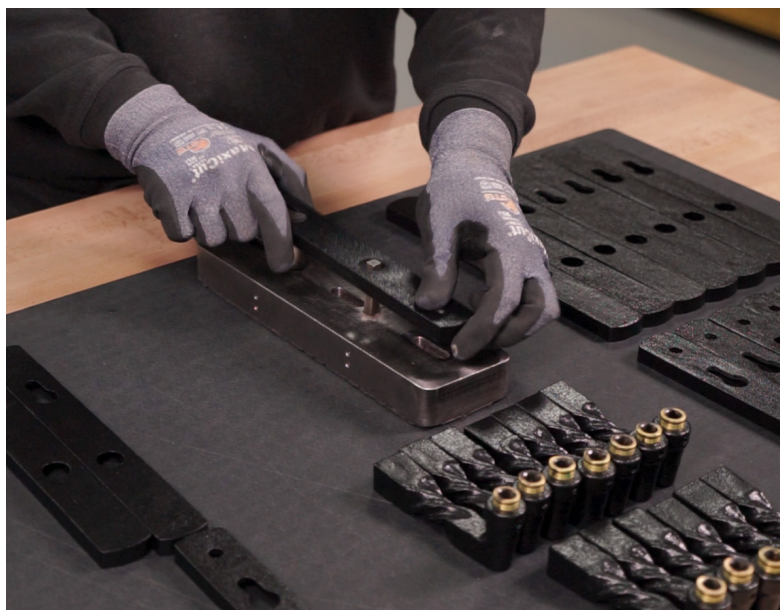

The People Behind the Brand



Our team of hardware specialists are here to help and provide you with the best solution for your project.

As a customer said *"Coastal actually care, they know what they're talking about and can give you advice".*



COASTAL

Shaping the future.

Talk to us:

CUSTOMER SERVICES TEAM

Contact the Customer Services Team for placing orders or any technical queries on sales@coastal-group.com or 01726 871 025.

SALES TEAM

Contact the Sales Team to arrange Face-to-Face visits or Video Calls on sales@coastal-group.com or 01726 871 025.

FINANCE TEAM

Contact the Finance Team for accounts queries on accounts@coastal-group.com or 01726 871 732.

With your ongoing support



Visit our New Brand Centre

Looking to develop new door or window ranges? Like to see and feel the quality of our product? Or have a bespoke hardware requirement you'd like to discuss?

Visit us in our new Brand Centre where we have a whole range of door and window hardware and production models on display for you to try for yourself.



BRAND CENTRE



y One



The benefits of using Stainless Steel instead of Iron for Antique Hardware

Black Antique hardware has always traditionally been made from iron. This is one of the biggest causes of failure in antique hardware.

As a ferrous metal, iron is susceptible to rusting so as soon as it is used on external hardware and exposed to the elements the deterioration begins. The hardware soon not only fails but causes rust streaks and staining down your door.

Stainless Steel on the other hand is a steel alloy metal containing chromium. The chromium reacts with the oxygen in the air and forms a protective layer that makes stainless steel highly resistant to corrosion and rust.

This makes stainless steel a much more suitable material for manufacturing external hardware from. It is why we use stainless steel as the base material for all of our DURATIQUETM Hardware, NOT iron.

The stainless steel base material of DURATIQUETM Hardware combined with an electrostatic polymer top coating has enabled us to achieve a world class corrosion resistance rating for Black Antique Hardware of Class 5 in a Salt Spray Test.

So wherever your doors and windows are installed, by fitting DURATIQUETM hardware you can have peace of mind.



CO7100C

Barley Twist

Lever Door Handle



- Narrow backplate with traditional 'barley twist' design lever handle.
- Suitable for multipoint door locks.
- Made from stainless steel base material to prevent it corroding.
- Class 5 Salt Spray Tested
- Heavy duty spring cassette for a solid, dual lever action
- Durability tested to BS EN 12217:2003 - 200,000 cycles
- Stainless steel fixings to match finish of handle
- Designed and Built in the UK
- Complete with fixing pack for door thicknesses of between 44-68mm.
- Back plate CNC machined to ensure consistency of screw holes and handle centres.



PART NUMBER	PRODUCT DESCRIPTION	FINISH	UNITS
CO7100C-TMB	DURATIQUETM Villand Antique multipoint door lock handle	TMB	Pair

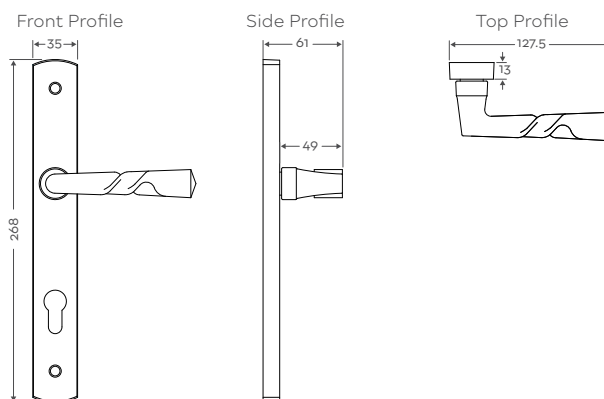

Visit www.coastal-group.com for CAD drawings

CO7200C

Bow Design Lever Door Handle



- Narrow backplate with traditional 'bow' design handle.
- Suitable for multipoint door locks.
- Made from stainless steel base material to prevent it corroding.
- Class 5 Salt Spray Tested
- Heavy duty spring cassette for a solid, dual lever action.
- Durability tested to BS EN 12217:2003 - 200,000 cycles
- Stainless steel fixings to match finish of handle.
- Designed and Built in the UK
- Complete with fixing pack for door thicknesses of between 44-68mm.
- Back plate CNC machined to ensure consistency of screw holes and handle centres.



PART NUMBER	PRODUCT DESCRIPTION	FINISH	UNITS
CO7200C-TMB	DURATIQUE™ Bow Design antique multipoint door lock handle	TMB	Pair

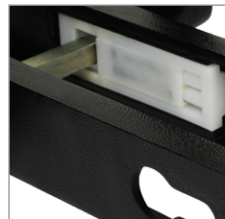

HD Spring Cassette



Stainless Steel Fixing



Dual Sprung Action

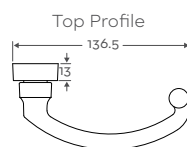
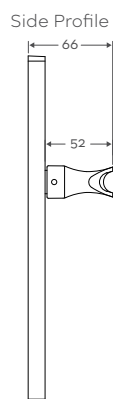
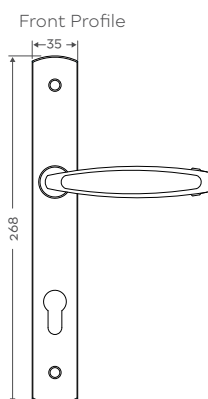

Visit www.coastal-group.com for CAD drawings





CO7300C

Narrow Curly Tail Lever Door Handle



- Narrow backplate with traditional 'Curly Tail' design lever handle.
- Suitable for multipoint door locks.
- Made from stainless steel base material to prevent it corroding.
- Class 5 Salt Spray Tested
- Heavy duty spring cassette for a solid, dual lever action
- Durability tested to BS EN 12217:2003 - 200,000 cycles
- Stainless steel fixings to match finish of handle
- Designed and Built in the UK
- Complete with fixing pack for door thicknesses of between 44-68mm.
- Back plate CNC machined to ensure consistency of screw holes and handle centres.

PART NUMBER	PRODUCT DESCRIPTION	FINISH	UNITS
CO7300C-LH-TMB	Narrow Curly Tail Multipoint Door Lock Handle	TMB	Pair
CO7300C-RH-TMB		TMB	Pair

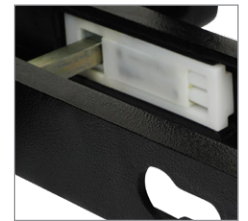

HD Spring Cassette



Stainless Steel Fixing

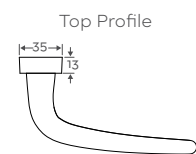
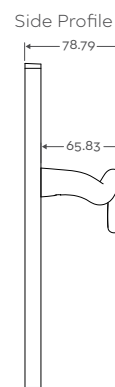
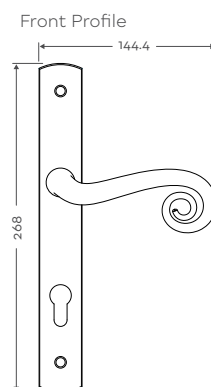

Right hand drawing shown

Visit www.coastal-group.com for CAD drawings

CP30



Classic Cylinder Pull

- High quality traditional style euro cylinder pull set.
- Back-to-Back fixing method makes it difficult for the cylinder pull fitted on the exterior of the door to be removed.
- Manufactured from a base material of 316 Marine Grade Stainless Steel.
- Class 5 Salt Spray Tested.

PART NUMBER	PRODUCT DESCRIPTION	FINISH	UNITS
CP30-TMB	Back to back euro cylinder pull	TMB	Set



External Cylinder Pull

Front Profile

Side Profile

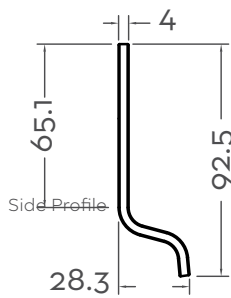
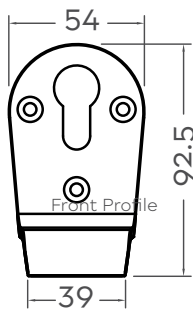

Internal Cylinder Pull

Front Profile

Side Profile

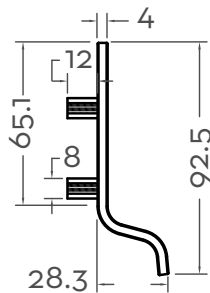
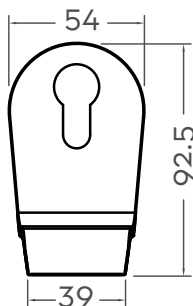

Visit www.coastal-group.com for CAD drawings



DKB225



Door Knocker

- High quality traditional ring door knocker and striker plate.
- Bolt-through and secret fixings.
- Class 5 Salt Spray Tested

PART NUMBER	PRODUCT DESCRIPTION	FINISH	UNITS
DKB225-TMB	Door Knocker	TMB	Each



Front Profile

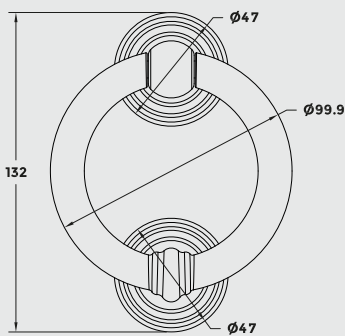

Side Profile

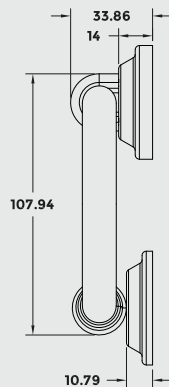

Bottom Profile

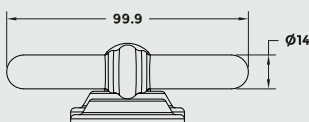

SE35



Slimline Escutcheon

- A slimline round escutcheon suitable for euro profile cylinders.
- Fixings concealed behind clip-on cover.
- Manufactured from 316 Marine Grade Stainless Steel.
- Class 5 Salt Spray Tested.

PART NUMBER	PRODUCT DESCRIPTION	FINISH	UNITS
SE35-TMB	Slimline round euro profile escutcheon	TMB	Each



Fixing Plate

Front Profile

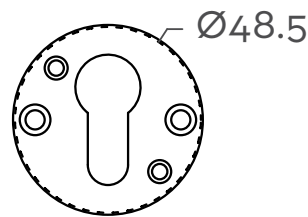

Side Profile

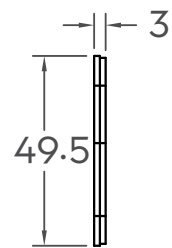

Cover Plate

Front Profile

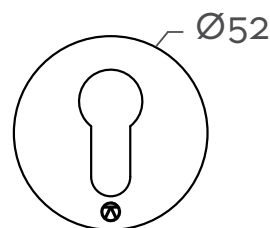

Side Profile

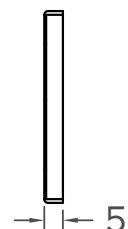

Visit www.coastal-group.com for CAD drawings

KM388

Centre Door Knob



- Fixed round centre classic door knob.
- Mounted on round rose.
- Solid 316 Marine Grade Stainless Steel.
- Class 5 Salt Spray Tested.
- 2 x KM388 can be fixed back-to-back.

PART NUMBER	PRODUCT DESCRIPTION	FINISH	UNITS
KM388-TMB	Centre door knob	TMB	Each



Side Profile

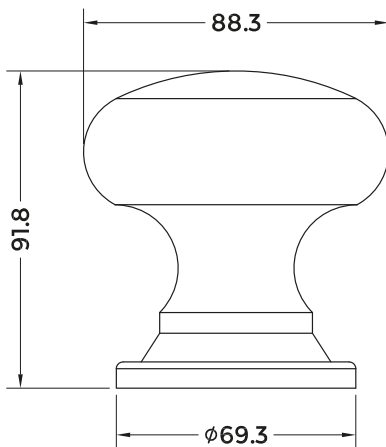

Visit www.coastal-group.com for CAD drawings





LP400

Sleeved Letter Plate



- High quality sleeved letter plate designed to suit both classic, heritage and contemporary style doors.
- Achieved 'Best in Class' BS6375-1 Weather Test results against air, wind and water.
- Successfully used in a PAS24 Security Test.
- Integral gaskets, brushes and telescopic liner for enhanced weather and draught protection.
- Built-in inner security flap to help prevent a 'fishing' attack.
- Designed and built in the UK to ensure consistency of quality.
- Manufactured from 316 Marine Grade Stainless Steel.
- Ideal for use where corrosion levels are high such as coastal environments and with acidic timbers.
- Air Permeability: BS EN 12207:2000, 600 Pa, Class 4
- Water Tightness: BS EN 12208:2000, 6000 Pa, Class A9
- Wind Resistance: BS EN 12210:2001, 3000 Pa, Class A5
- Suits door thickness up to 68mm.
- Class 5 Salt Spray Tested.

PART NUMBER	PRODUCT DESCRIPTION	FINISH	UNITS
LP400-TMB	Sleeved letter plate to suit door thickness up to 68mm	TMB	Each

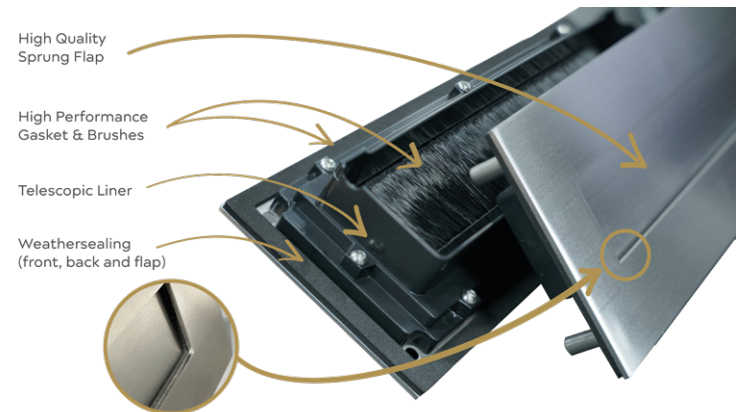

Manufactured from a base material of 316 Marine Grade Stainless Steel

DESIGNED & BUILT IN THE UK





Internal Component

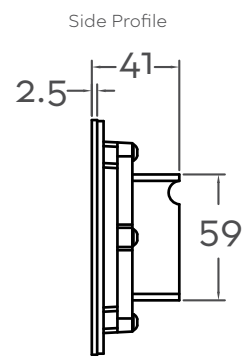
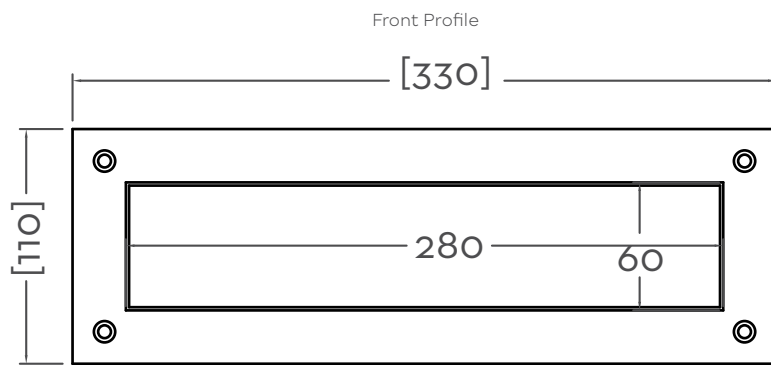

External Component

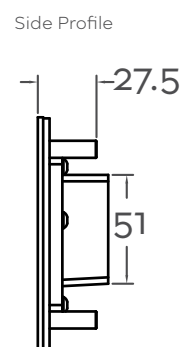
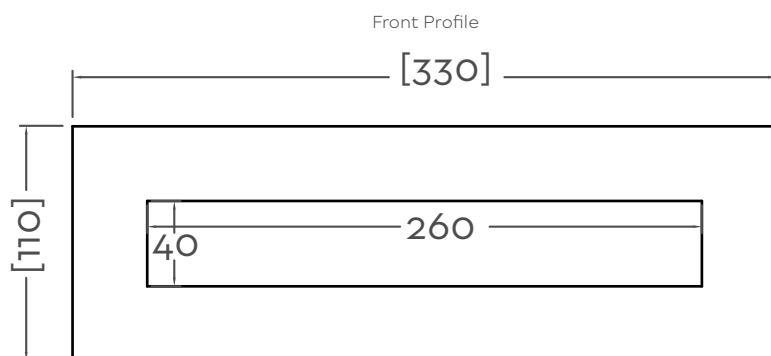

You might also be interested in...

Our new Curly Tail and Bulb End Antique Window Espag Handles. Not part of our DURATIQUÉ range but available in the same Textured Matt Black finish. Features include:

- Push button to open, with key to deadlock for added security.
- Tested to PAS24 for enhanced security.
- Tested to 50,000 cycles for durability.
- Salt spray tested to 480 hours for corrosion resistance.

For more information contact us on sales@coastal-group.com or call 01726 871 025.

CO8473

Curly Tail Espagnolette Handle



CO8477

Bulb End Espagnolette Handle



Hardware Product Care and Maintenance

To help you care for the DURATIQUE™ hardware range please follow the guidelines below.

During installation and whilst building work is being carried out the hardware should be covered to protect it from dust, dirt and scratching.

Immediately after fitting and installation

- Product should be cleaned using a soft cloth and mild soapy water then dried immediately with a clean, soft cloth.

Monthly Care and Maintenance

- Clean regularly with a soft, dry cloth or duster.
- Product should be washed monthly using a soft cloth and mild soapy water then dried immediately with a clean, soft cloth - especially if fitted on or near the coast.
- Fingerprints can be removed by washing product as above.
- The above procedure should be followed with an application of good quality, non-abrasive car wax polish, gently applied, to protect the finish.

Six Monthly Care and Maintenance

- Lubricate any moving parts with a suitable PTFE Grease such as GLS200 available from www.coastal-group.com.

Please Note

- DO NOT use oily rags or greasy cloths when wiping the product surface.
- DO NOT use bleach, abrasive cleaners, caustic or acid based cleaning materials, or detergents containing chloride, or any other strong household cleaning products.
- DO NOT use abrasive materials, files or other hard objects against the product surface.
- This product should be protected from dust and dirt during any construction work.



Marketing Resources

Ask about our marketing resources available including Showroom Display Boards, Posters, and high quality product images for your brochures and website.

Contact us on sales@coastal-group.com or 01726 871 025 to discuss your requirements. Or visit our website to download CAD files, data cards and product images.

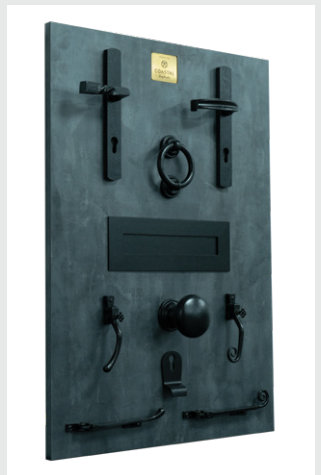
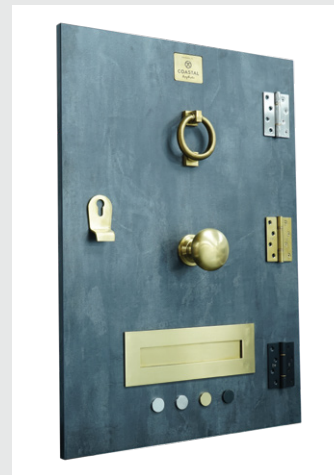



"Coastal's range of premium hardware accessories is the ideal finishing touch for our high-end timber core composite doors. Aesthetically, the products look fantastic, they are perfectly in tune with consumer trends and can be styled to create a range of looks from traditional to ultra-modern."

"The service we have received from Coastal when promoting their range of premium hardware accessories is first class. Product images, promotional copy and samples are always readily available. The sample boards that Coastal manufacture have been a fantastic addition to our own retail showroom."

Endurance Doors

Inspiration Gallery

Showcasing some of our customers' quality workmanship with our DURATIQUE™ hardware featured.





Hints and Tips to Improve your Project Photography

Do you struggle with taking good photos that showcase the quality of your work? We all fall into the same trap but making a few small tweaks can make a huge difference to the quality of your photograph. We've listed below some points we've found helpful during our own photoshoots.

Adjusting the image resolution on your phone/camera

- Use the best quality image settings on your phone/camera.
- When sending the photos, please make sure to email them as original files without reducing file size.

Include as much as you can within the photo

- Holding your phone/camera landscape instead of portrait. Simply turning your phone/camera on its side gives more of an area to work with your photo.
- Try and include as much of the house or room in a shot as possible to allow your viewer to understand the concept of your work better.
- Frame the door/window so that there's some extra space around it. This gives the building context and will focus the eye on your work.

Photograph from an angle

- Taking the photograph from an angle shows the architectural lines and gives more dimension.
- Choose your angle, kneel down, and take the shot upwards – a shot taken around 100cm from the floor is best. An angled view taken low and from the side will also make a great shot.

Stabilise your phone/camera by resting it on an object

- Try resting your phone/camera on something, this will help keep the angle straight and stop it from shaking/blurring.

Watch out for any reflections in your photos

- Try not to catch yourself or any of your equipment reflecting in the glass.

Be mindful of the weather forecast and avoid using the flash

- Sunshine and blue skies showcase your work at its best. If you are outside and have an outside light source use it, as it will highlight your work. If you are indoors then use as much natural light as possible; open blinds, curtains, etc. and turn the lights on. Whether indoors or out, ensure that your light source is behind you. Avoid using the flash as it tends to result in an awkward reflection or a bad glare.

Remember to tidy up before you take a photo

- Cleaning the doors, windows and hardware and tidying up both inside and outside before you take your photo will create a much better photo and showcase the quality of your workmanship.

Take as many photos as you can

- Taking multiple photos will give you a variety to choose from and capture your work from different perspectives. The first photo you take is often not the best one.

Remember to tag Coastal Group on social media





Like to see your finished door and window projects feature on our website?

Send Hi-Res (original file) photos of your projects to: marketing@coastal-group.com

Looking for inspiration? Visit the 'OUR WORK' section on our website to see examples and case studies of some of the work our clients have produced using our products.



COASTAL

About us
News
Quick Order
Quick Quote
Show VAT
LOG IN

Q

Call: 01726 871025
🛒 Your Basket

INSPIRATION
PRODUCTS
BRANDS
SERVICES
RESOURCES
HELP

CO7200C & LP400 DURATIQUÉ Door Handle and Letter Plate in Devon

This property in Devon isn't far from the coast. The owner wanted to keep a traditional look and feel to their property but without the issues that typically come with Black Antique hardware made from malleable iron.

With this in mind, our CO7200C DURATIQUÉ Door Handle and LP400 DURATIQUÉ Letter Plate were fitted to this Solidor 'cottage style' door.

Made from Stainless Steel, our DURATIQUÉ Hardware Range provides a traditional antique look and feel but with modern, high quality performance and durability. The stainless steel base prevents corrosion and the screw holes and handle centres are CNC machined for consistency.

[VIEW CO7200C DURATIQUÉ DOOR HANDLE](#)

[VIEW LP400 DURATIQUÉ LETTER PLATE](#)

<
>

27

Shaping the future.



COASTAL

COASTAL GROUP

Head Office: Global House, Bojea Industrial Estate, St Austell, Cornwall, PL25 5RJ, UK

T 01726 871 025 E sales@coastal-group.com W coastal-group.com

Follow us on:



© Coastal Specialist Ironmongery Ltd 2023