



*Slam Shut Multipoint Lock for  
Heritage Doors - Autolock*

ML580 HERITAGE PLUS DOOR - AV4 LOCKING



**COASTAL**

*Shaping the future.*

# HERITAGE PLUS MULTIPOINT DOOR LOCK - PREMIUM AUTO



Provides a traditional heritage look with the cylinder located approx at shoulder height on the door



Can be used with either a cylinder pull or a pull handle and also our Biometric Fingerprint Scanner

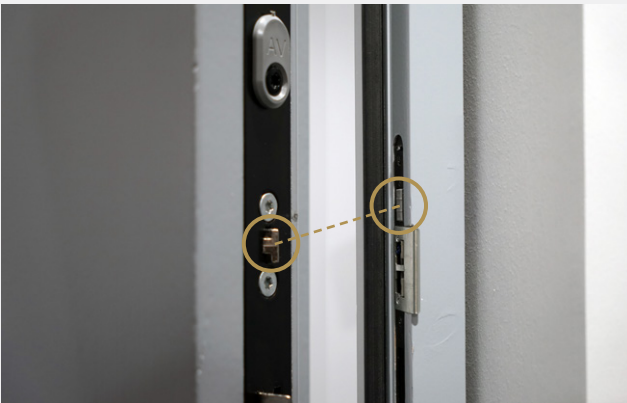

Magnet only activates the hook bolts once door is closed, auto locking the door and preventing damage to frame



Hook bolts provide extra security and enhanced weathersealing

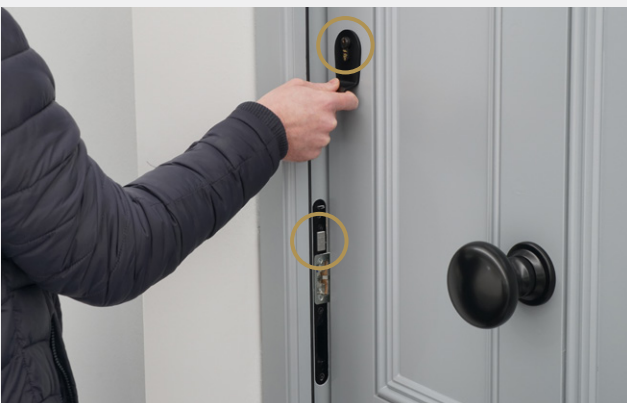

The new practical Daytime Latch can be activated for times when flexible entry from outside is required without the use of a key



Tested to PAS24 and Secured by Design Approved

# HERITAGE PLUS MULTIPOINT DOOR LOCK - PREMIUM AUTO

## LOCK CODES

LOCK PART NUMBER	HANDING	BACKSET	FACEPLATE	FINISH	UNITS
ML580R-45-SV	Universal	45mm	20mm Radius	SV	Each
ML580R-55-SV	Universal	55mm	20mm Radius	SV	Each
ML580R-55-MSB	Universal	55mm	20mm Radius	MSB	Each

## KEEP CODES

KEEP PART NUMBER	PRODUCT DESCRIPTION	HANDING	CENTRE	FINISH	UNITS
MK37-SV	Flush adjustable hook keep	Universal	12mm	SV	Each
MK37-MSB	Flush adjustable hook keep	Universal	12mm	MSB	Each
MK48-28-LH-SV	Centre keep c/w daylatch & magnet	Left	28mm	SV	Each
MK48-28-RH-SV	Centre keep c/w daylatch & magnet	Right	28mm	SV	Each
MK48-33-LH-SV	Centre keep c/w daylatch & magnet	Left	33mm	SV	Each
MK48-33-LH-MSB	Centre keep c/w daylatch & magnet	Left	33mm	MSB	Each
MK48-33-RH-SV	Centre keep c/w daylatch & magnet	Right	33mm	SV	Each
MK48-33-RH-MSB	Centre keep c/w daylatch & magnet	Right	33mm	MSB	Each



### BIOMETRIC

Lock can also be used with our Biometric Door Lock Kit.



## HERITAGE PLUS MULTIPOINT DOOR LOCK - PREMIUM AUTO

### DAYTIME LATCH FEATURE



#### Blue switch in 'down' position

- Daytime Latch activated - Door can be pushed and pulled to open and close without key
- Prevents door from blowing open
- Very convenient for example when bringing shopping in from car



- To deactivate Daytime Latch simply push blue switch up



#### Blue switch in 'up' position

- Daytime Latch deactivated
- Duo Hook Locks fired by magnet once door is closed
- Door securely locked once more
- Key required to unlock and open door

### Keep Handing (as viewed from outside)

Left Hand Lock

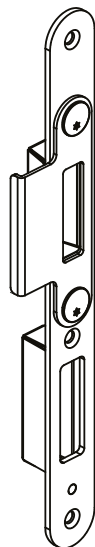

Right Hand Lock

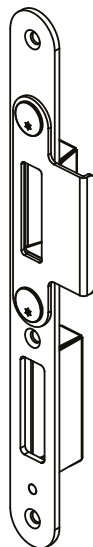

RECOMMENDED DETAIL FOR ML580 (AV4) LOCKS

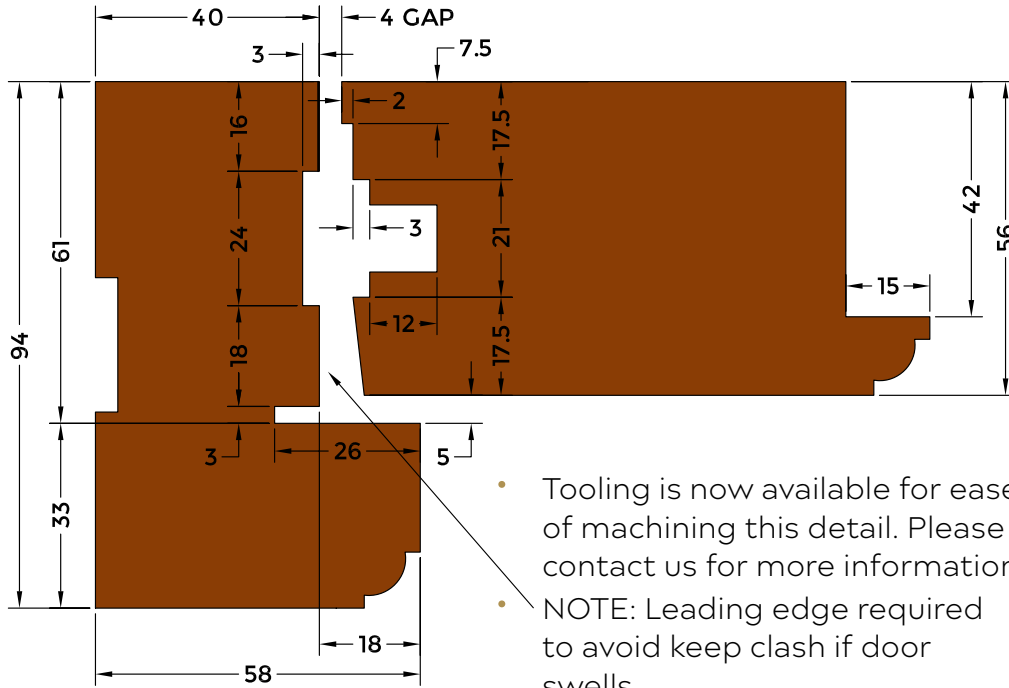

- Tooling is now available for ease of machining this detail. Please contact us for more information
- NOTE: Leading edge required to avoid keep clash if door swells
- The critical dimension is that the face plate of lock & main body of the keep is 4mm apart

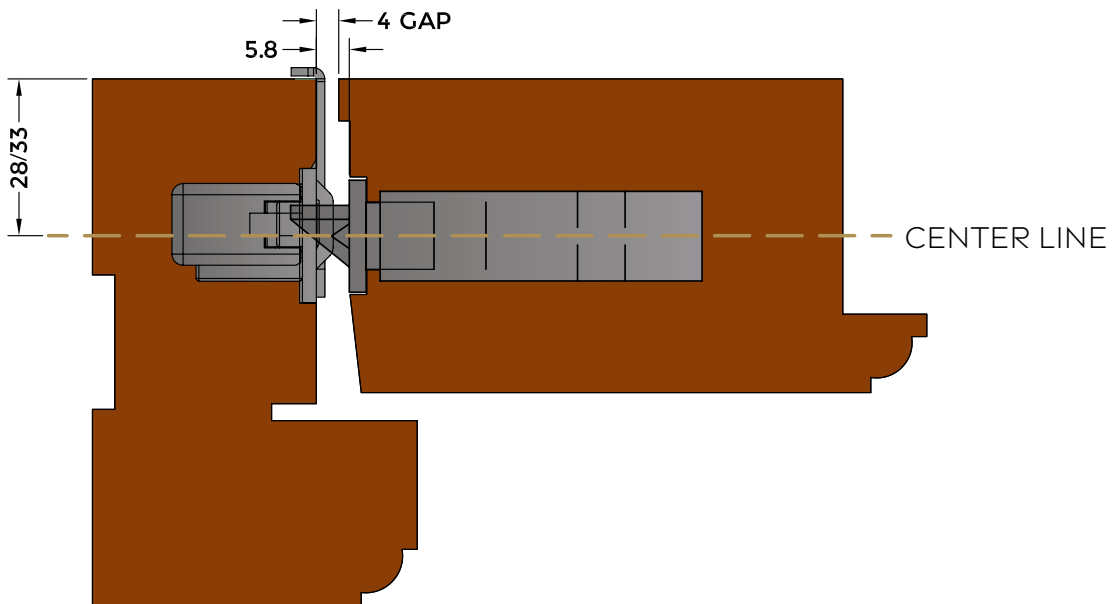

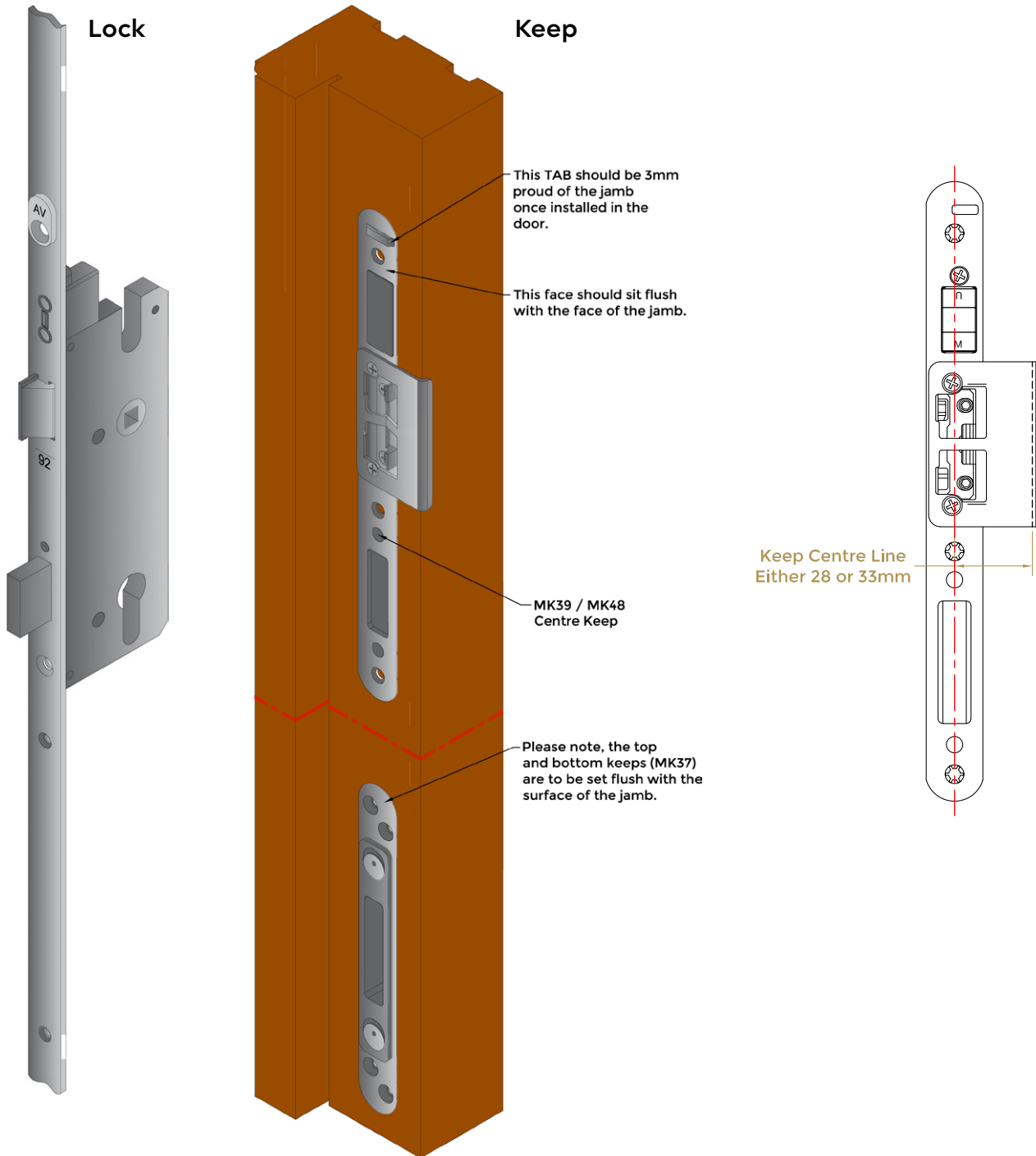

Some tips to help when fitting the MK48 & MK37 keeps:

1. Ensure your frame/door section are correct - make sure you've got the correct amount of clearance, see drawing on page 5.
2. Ensure keeps are aligned as shown on pages 7-8.
3. Allow clearance for daylatch to work - follow routing preparation as shown on page 9.
4. We advise HQ4 hinges to be used with the auto locks.
5. Use Shimwell Hinge Packers to simplify future door adjustments and maintenance.
6. Use Deventer Weatherseal for lower operating force.

**WINKHAUS MULTI-POINT LOCK ALIGNMENT GUIDE**

Winkhaus AV4 centre keeps (MK48) have alignment markings to help ensure correct alignment of centre keep to lock (ML580). Please follow the below for correct keep to lock alignment:

1. Align the lower marking on the striker plate of the centre keep to the spindle centre line marking on the lock faceplate.
2. Once centre keep is correctly aligned, the dimension from the spindle centre line to the bottom of the top keep is 649mm as shown on drawing on page 8.
3. Once centre keep is correctly aligned, the dimension from the spindle centre line to the top of the bottom keep is 665.5mm as shown on drawing on page 8.

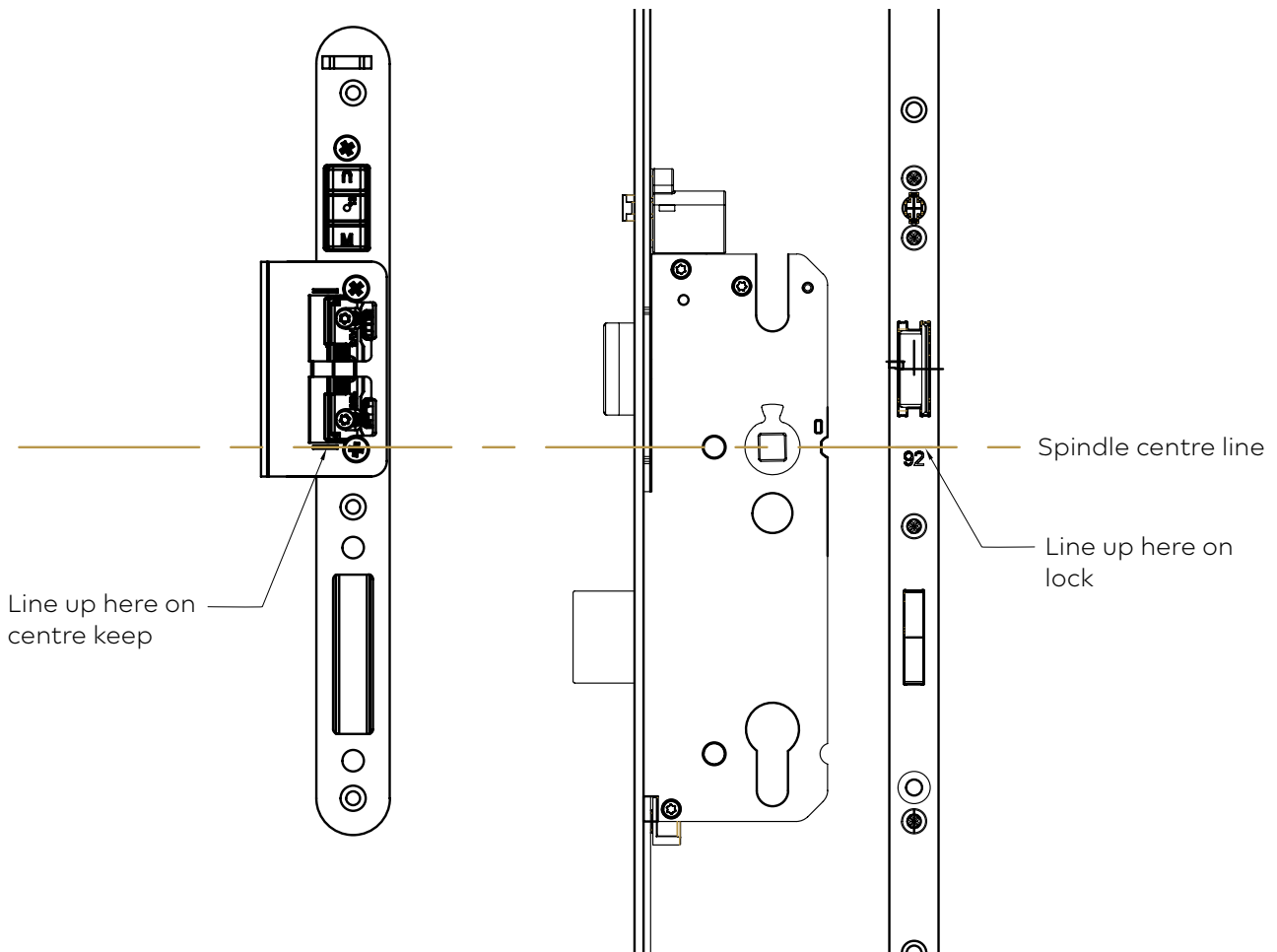
MK48 Keep with  
Daylatch

ML580 Lock

45MM & 55MM BACKSET (BS) LOCK - FRAME/SASH ROUTER DETAIL

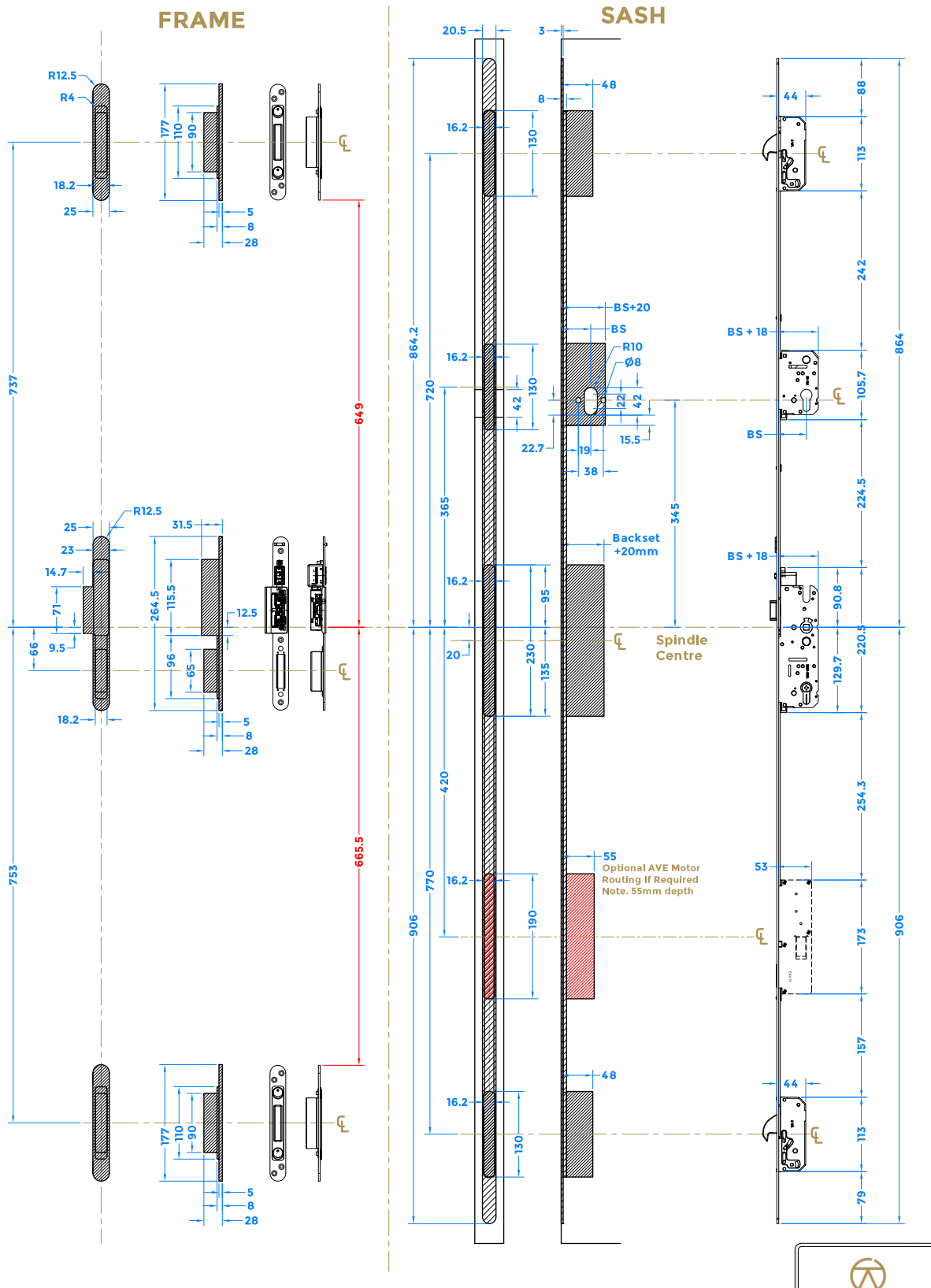

**MK48 CENTRE KEEP - FITTING GUIDE & ROUTER DETAIL**

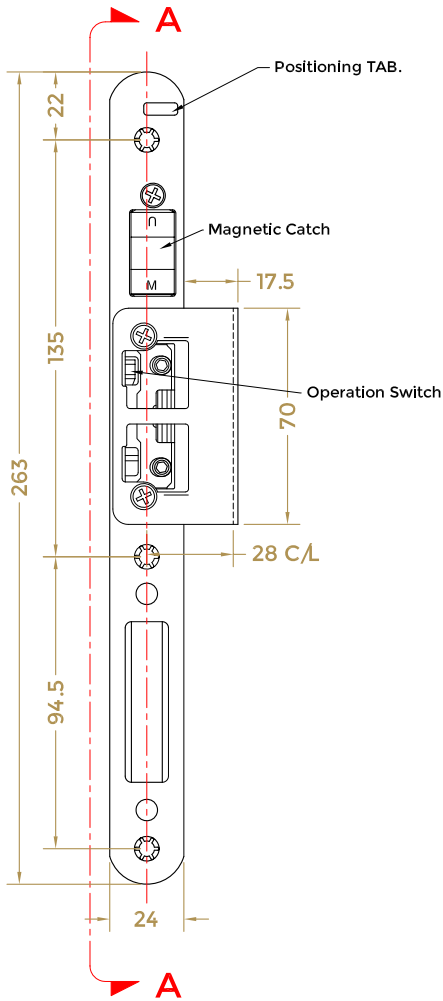

**MK48-28-RH**

For doors up to 56mm thick

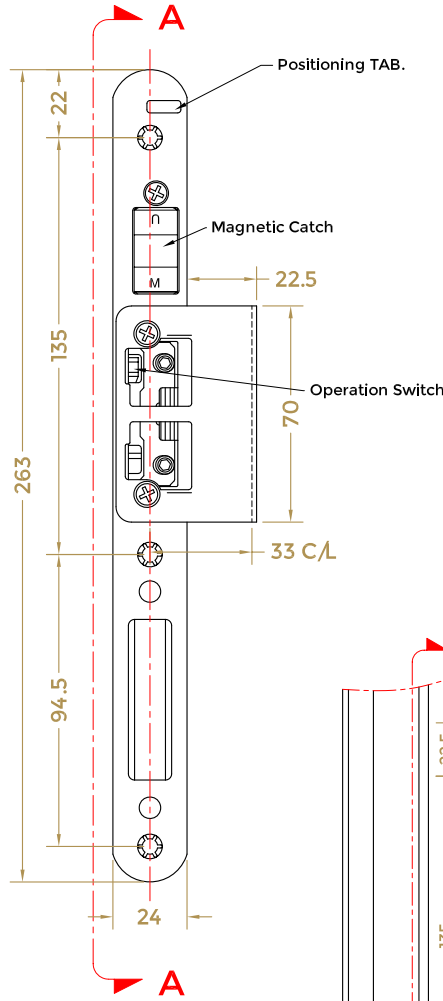

**MK48-33-RH**

For doors up to 66mm thick

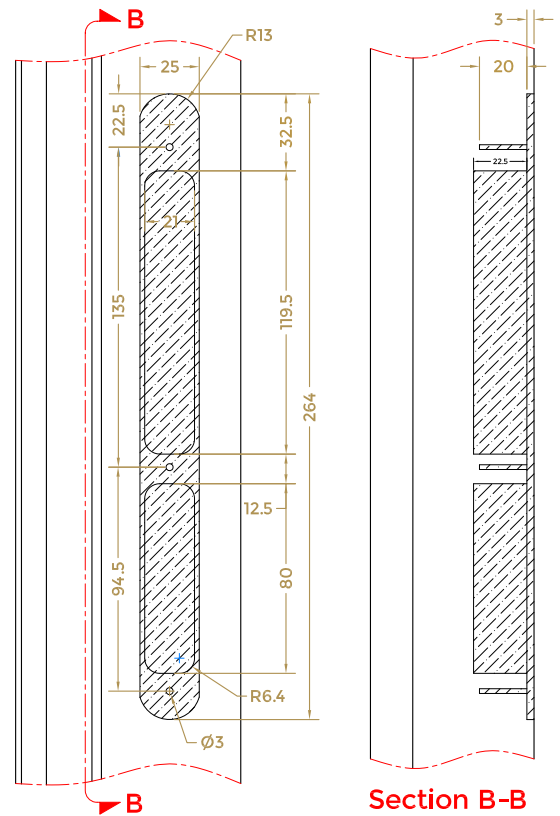
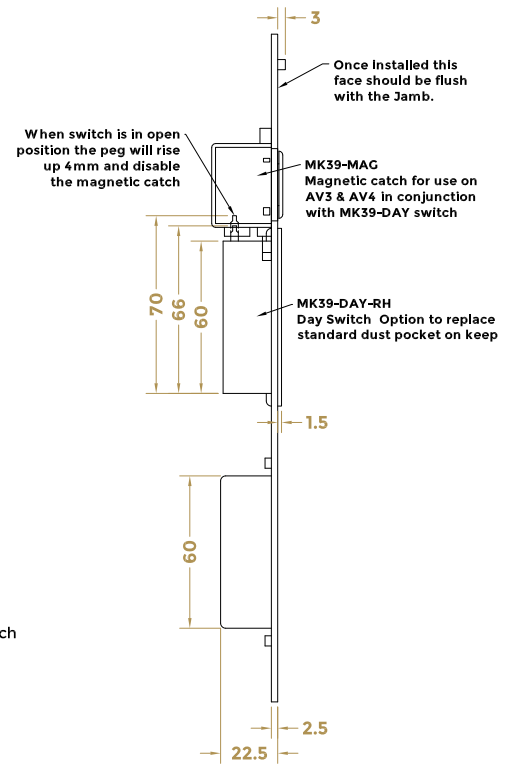

**Routing Prep Details**

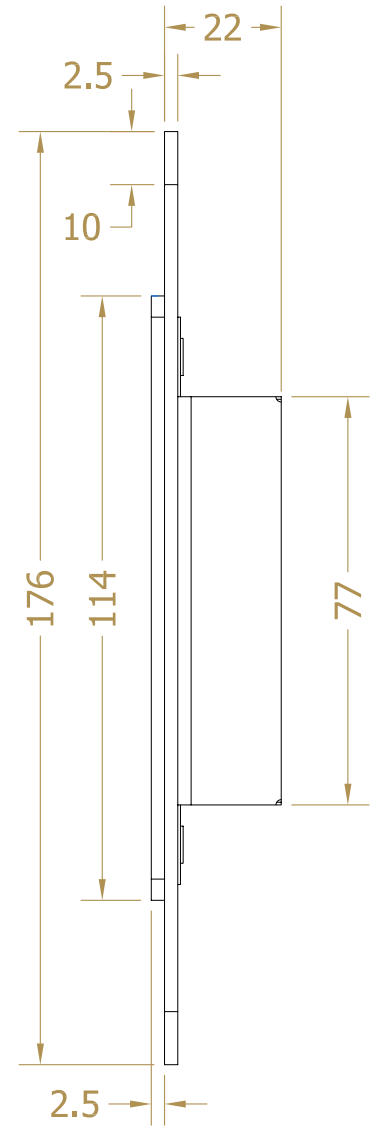
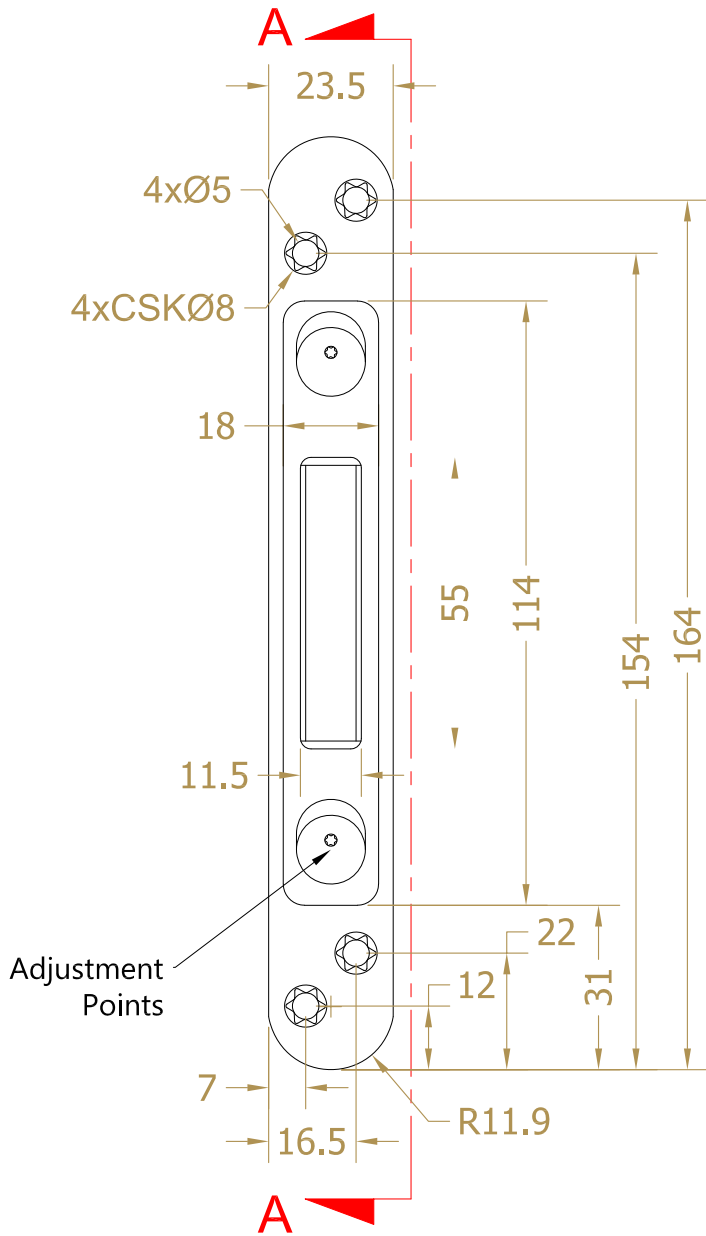

**Section A-A**

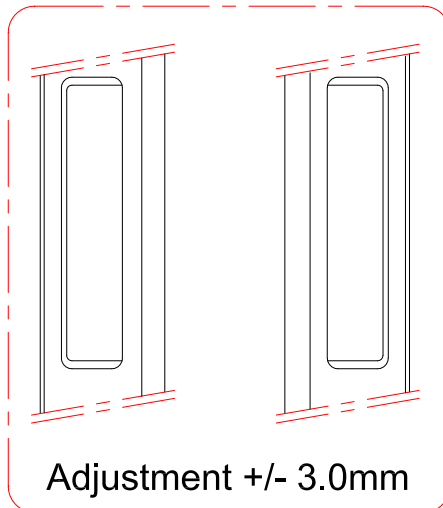

## MAINTENANCE AND LUBRICATION GUIDE

---

Winkhaus locking systems are put through very stringent tests to meet the requirements of today's environment, including cycle testing.

The current requirement for PAS 23/24 is 50,000 full cycles of the door-set in order to simulate 10 years average use.

The requirement for maintenance is totally dependent on usage and environment, i.e. In areas of high dust or corrosive atmospheres, the requirement for lubrication will be more frequent than normal.

We therefore recommend that a light application of our GLS200 Lubricant Spray be used into the apertures of the hooks, dead-bolt and latch and into both sides of the cylinder. In normal usage Bi-annual application would be more than sufficient.

To prevent any damaging effect to the corrosion protection of Winkhaus fittings, only PER neutral cleaning and care agents should be used, which do not contain any abrasives.

We also strongly recommend that the door set is checked over for any movement, swelling or distortion of either sash or frame, if necessary check for debris of any kind interfering with any of the moving parts behind the mechanism itself. This operation will require the mechanism to be removed and replaced by a competent person. Any loose or missing fixing screws should be tightened or replaced as required.

Under no circumstances should any aspect of the lock or cylinder be tampered with in any way, as this may affect both the serviceable life and guarantee.



## WINKHAUS AV4 – ML4120 &amp; ML580 TROUBLESHOOTING GUIDE

Whilst every effort is made to ensure trouble-free operation of the door locking system the table below may help to remedy any issues experienced.

To help diagnosis we firstly suggest checking full operation with the door open.

SYMPTOMS	POSSIBLE CAUSES	SUGGESTED REMEDY
Door closing difficulty	Dry Latch	Apply light lubrication (GLS200) to the latch, aperture and keep contacting surface
Stiff key operation	Door not latched correctly (This can be proven by temporarily holding the hooks back with a suitable tape)	Relieve pressure on the hooks by gently pulling on the door externally or pushing internally to operate
	Incorrectly adjusted keeps (The latch is the compression point, the hook sides should not contact the keeps)	Adjust centre keep accordingly.
Unable to operate the locking system (Blocked)	Hooks fouling inside the keeps.. Door dropped or incorrectly positioned keeps	Attempt to lift the door leaf whilst operating the lock
	Excessive air gap to the lock side	Adjust the door leaf closer to the lock side
Door not latching (In secure mode)	Lock drive strip fouling on routing etc	Locate and relieve cause.
	Misaligned centre keep	Check centre lines
	Magnet stuck in	Check operation
	TAFA day switch engaged	Disengage
Door not releasing (In passive mode - Day switch engaged)	Latch keep movement impeded	Check and relieve
	Air gap too tight (Triggering operating snib)	Adjust air gap