

# 3 HEADED ESPAGNOLETTE HANDLE DRILL KIT

Product Code: TOOL-ESPJIG

LIT-DC-TOOL-ESPJIG

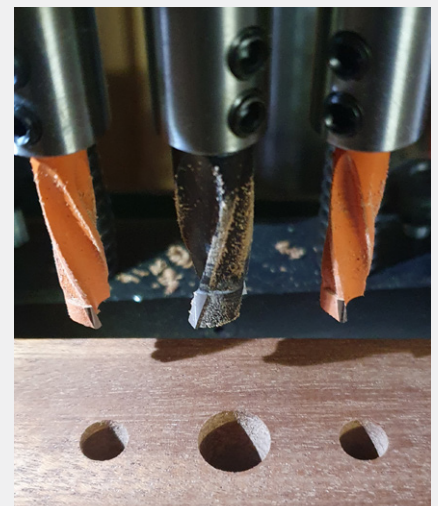
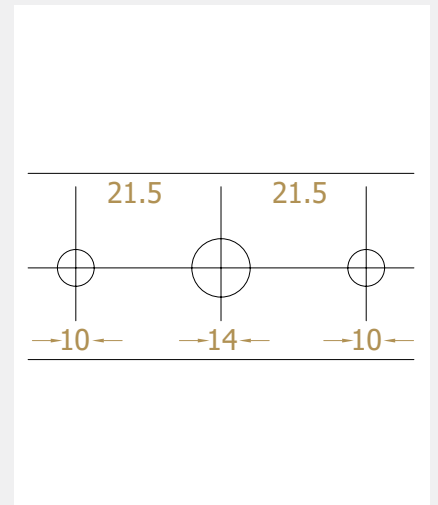
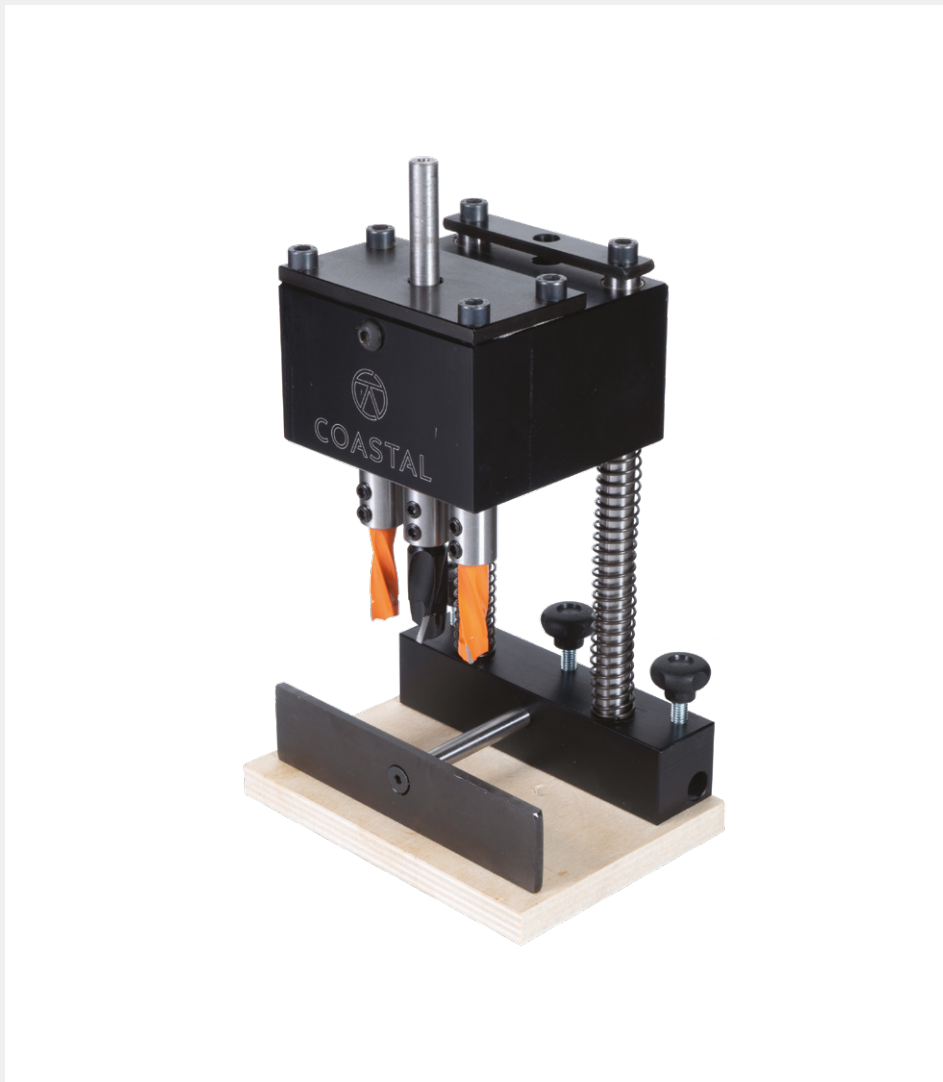

*Helping you achieve perfect handle alignment*

- Helps you achieve perfect alignment when pre-drilling screw holes for handles
- Works with wood, aluminium & PVC
- For use with all Coastal's espagnolette handles
- Can be used with hand drill or pillar drill
- Complete with 2 x 10mm and 1 x 14mm dowel drills



**COASTAL**

*Shaping the future.*

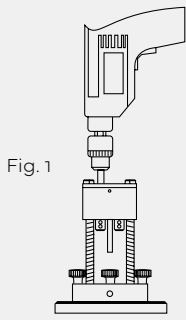

Fig. 1

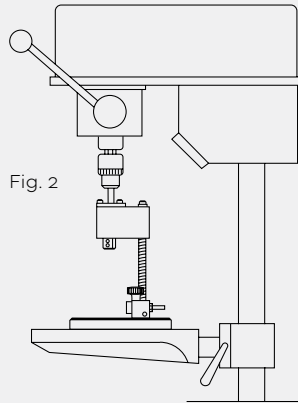
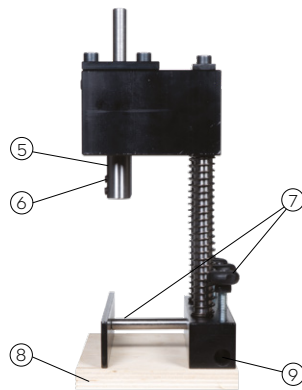
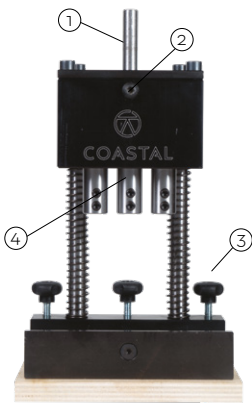

Fig. 2

When the jig has been set up, all that is required is an electric drill Fig.1 (recommended power 0.75kw) or alternative, a pillar drill Fig. 2



INSTRUCTIONS:

1. Drive for drill
2. Threaded hole for lubricating
3. Locking knob for stop reference rod function
4. Depth stop adjustment
5. Tool holder sleeve
6. Depth stop and lock screw
7. Equipment support table
8. Stop rod hole

Equipment setup and operating phases

Disassemble the support table (8) and position the equipment on a suitable surface for the type of work. Requires a rod with 10mm diameter. and length suitable for the job to be carried out and insert it in the hole (9). Position the reference stop and lock the whole assembly with the knobs (3). Fix one or more reference blocks on the work surface depending on the length of the window to be drilled. Finally, position the casement to be drilled (see Fig. 3).

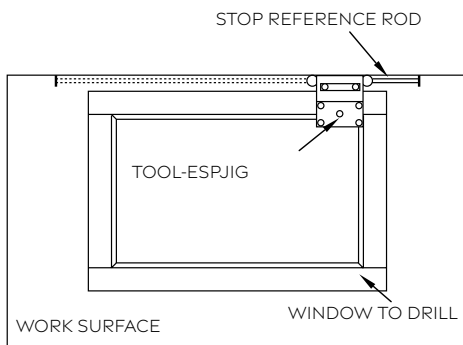
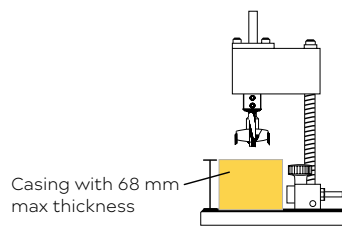
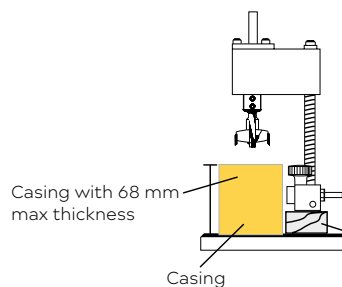

Fig. 3



For casings with 68mm. max. thickness your are suggested to use our TOOL-ESPJIG boring jig as shown in the drawing hereby



For casings with more than 68mm. thickness you can shim our TOOL-ESPJIG boring jig as shown in the drawing hereby by 78-68=10mm thickness of the shim to use

PART NUMBER	PRODUCT DESCRIPTION
TOOL-ESPJIG	3 Headed espagnolette handle drill kit



**COASTAL**

*Shaping the future.*