

FITTING GUIDE

KABA 3 STAR CYLINDER IMPORTANT INFORMATION

Prior to Fitting:

Please check cylinder for operation prior to fitting for any potential damage which may have occurred during transportation. Dropping the cylinder can cause the security pin to fire which disables the cylinder and makes it inoperative.

During Installation:

When fixing the cylinder into the door through the fixing screw point, as shown in diagram, take care to NOT overtighten the fixing screw. You may need to slacken off the fixing screw by a quarter turn during installation for the cylinder to operate correctly.

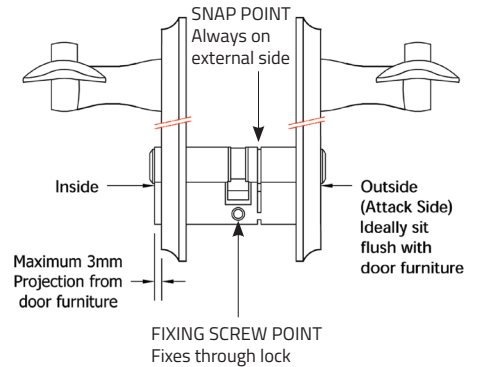
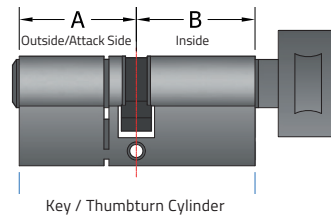
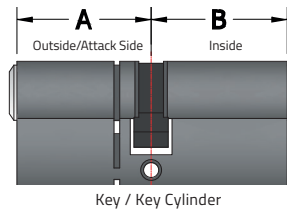

Installation:

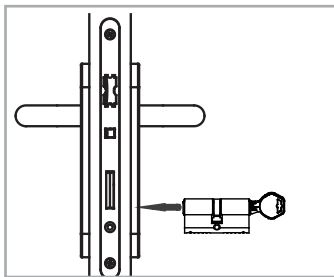

1. Push locking cylinder into lock.

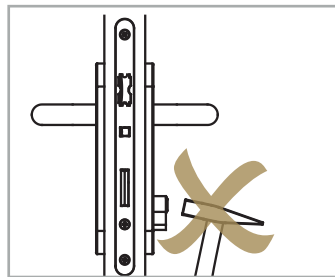

2. Do NOT use force when installing locking cylinder into the lock.

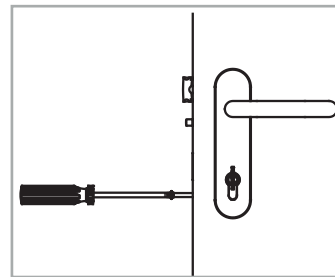

3. Secure locking cylinder with cylinder fixing screw using a manual screwdriver (max. tightening torque 5Nm).

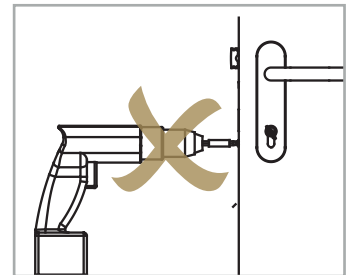

4. Do NOT use an impact driver, auto screwdriver or cordless or drill to tighten the fixing screw as this can cause the cylinder to bend and not function correctly.

Thumbturn Cylinder operation:

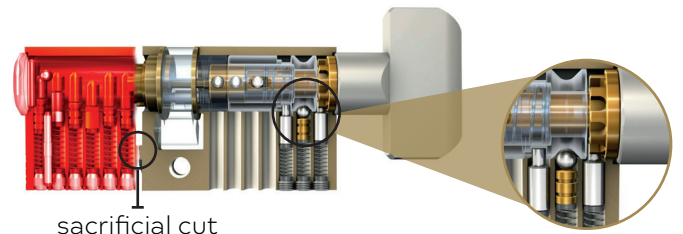
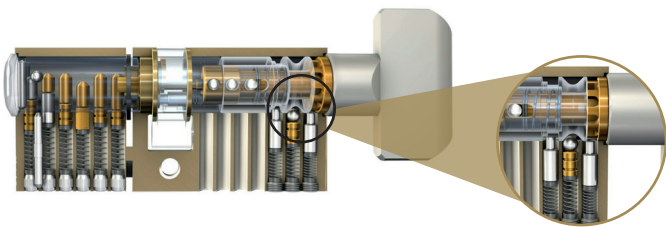

The thumbturn rotor is sprung-loaded, to ensure the cylinder can be operated from the inside in the event of the cylinder being attacked/snapped.

The cylinder has been designed to ensure any such attack leaves the person unable to operate the cylinder to gain access to the property. This is achieved by deadlocking the cam in the event of the front end of the cylinder being snapped at point of the sacrificial cut (external). This pin ensures the cam cannot be manipulated to disable the locking mechanism on the door.



COASTAL

Shaping the future.

FITTING GUIDE

KABA 3 STAR CYLINDER IMPORTANT INFORMATION

However, to ensure there remains a means of egress to any occupants, the deadlocking pin can be withdrawn by pulling the thumbturn outwards and rotating to unlock the door.

Note:

The thumbturn should not be used as a means to pull open the door. This will put undue stress on the cylinder which is not conducive to the cylinder operating at its optimum performance.

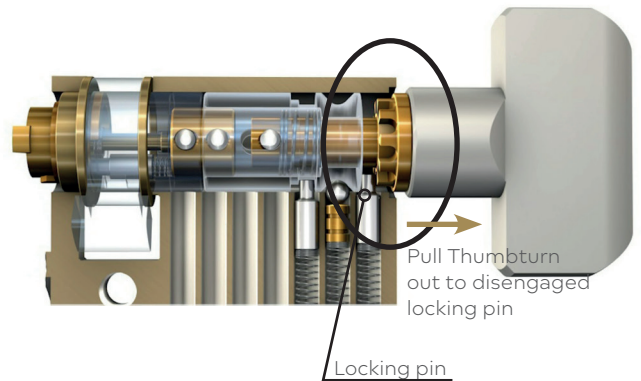

Euro Profile Cylinder Care and Maintenance

Strongly Recommended:

Never use other lubricants, for instance graphite, grease or oil and any other cleaning spray or agent containing oily substances in a KABA cylinder. These will encourage the accumulation of residue that in turn will achieve nothing more than the opposite - namely the creation of the equivalent of a grinding paste thus impairing the function and life of the cylinder.



COASTAL

Shaping the future.